

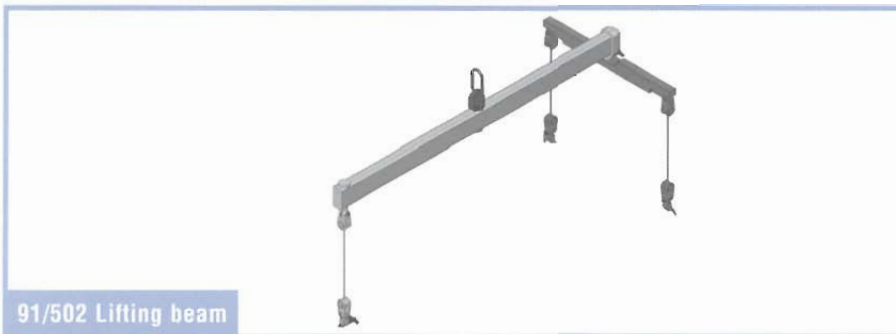

The cradle is used to support the APU for pre-installation work.

Easily manoeuvred thanks to its braked and castoring wheels.

Can be precisely positioned under the aircraft.



91/502 Lifting beam

Lifts the engine from transport container into cradle and from cradle into aircraft.

Different adaptors supplied with the hoist so that it suits several applications.

All parts tested and certified to the highest standards throughout manufacturing process.

