

AIRCRAFT APPLICATION SHEET FOR: 100/58 A400M AILERON, ELEVATOR AND SPOILER HOIST KIT



World class lifting and handling solutions

Didsbury Engineering Co Ltd

ISSUE 2 - EXTENSION TUBE ADDED - ADB - 25/09/07 - DCN 1133

ISSUE 3 - PICKUP TOOL, ELEVATOR APPLICATIONS AND BASE TUBE ADDED - MBH - 12/11/08 - DCN 1293

Telephone: +44 (0)161 486 2200
Facsimile: +44 (0)161 486 2211
Email: sales@didsbury.com
Web: www.didsbury.com

- A400M AILERON EHA
- A400M AILERON S/C
- A400M SPOILER 1 EBHA
- A400M SPOILER 2 S/C
- A400M HTP ELEVATOR S/C
- A400M HTP ELEVATOR EHA
- A400M PICK UP TOOL

100/58 KIT CONTENTS - TO BE USED IN CONJUNCTION WITH TAPE HOIST 100/1 (SUPPLIED SEPARATELY)

ITEM NO.	PART No.	DESCRIPTION	QTY.
1	100/47	TOP SHEATH STRAP ASSEMBLY	1
2	100/48	AILERON EHA SHACKLE ASSEMBLY	1
3	100/49	AILERON S/C AND HTP ELEVATOR SC SHACKLE ASSY	1
4	100/50	SPOILER 1 AND 2 AND HTP ELEVATOR EHA SHACKLE ASSY	1
5	100/77T2	1000mm EXTENSION TUBE ASSEMBLY	1
6	100/31T7	1200mm LONG BASE TUBE ASSEMBLY	1

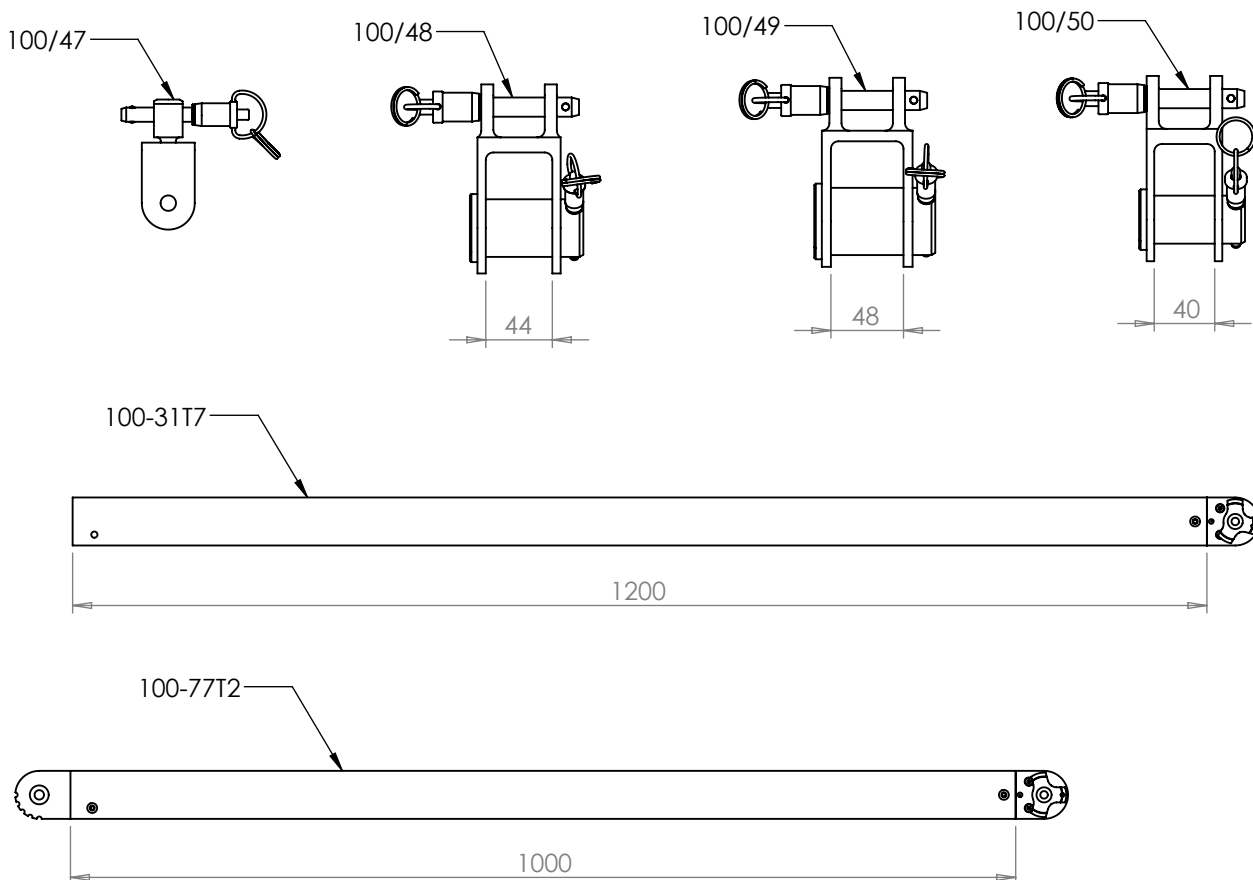

SWL: 100Kg
WEIGHT: 10Kg

AIRCRAFT APPLICATION SHEET FOR: 100/58

A400M AILERON EHA



World class lifting and handling solutions

Didsbury Engineering Co Ltd

Telephone: +44 (0)161 486 2200
Facsimile: +44 (0)161 486 2211
Email: sales@didsbury.com
Web: www.didsbury.com

ITEM NO.	PART No.	DESCRIPTION	QTY.
1	100/47	TOP SHEATH STRAP ASSEMBLY	1
2	100/48	AILERON EHA SHACKLE ASSEMBLY	1
5	100/77T2	1000mm EXTENSION TUBE ASSEMBLY	1

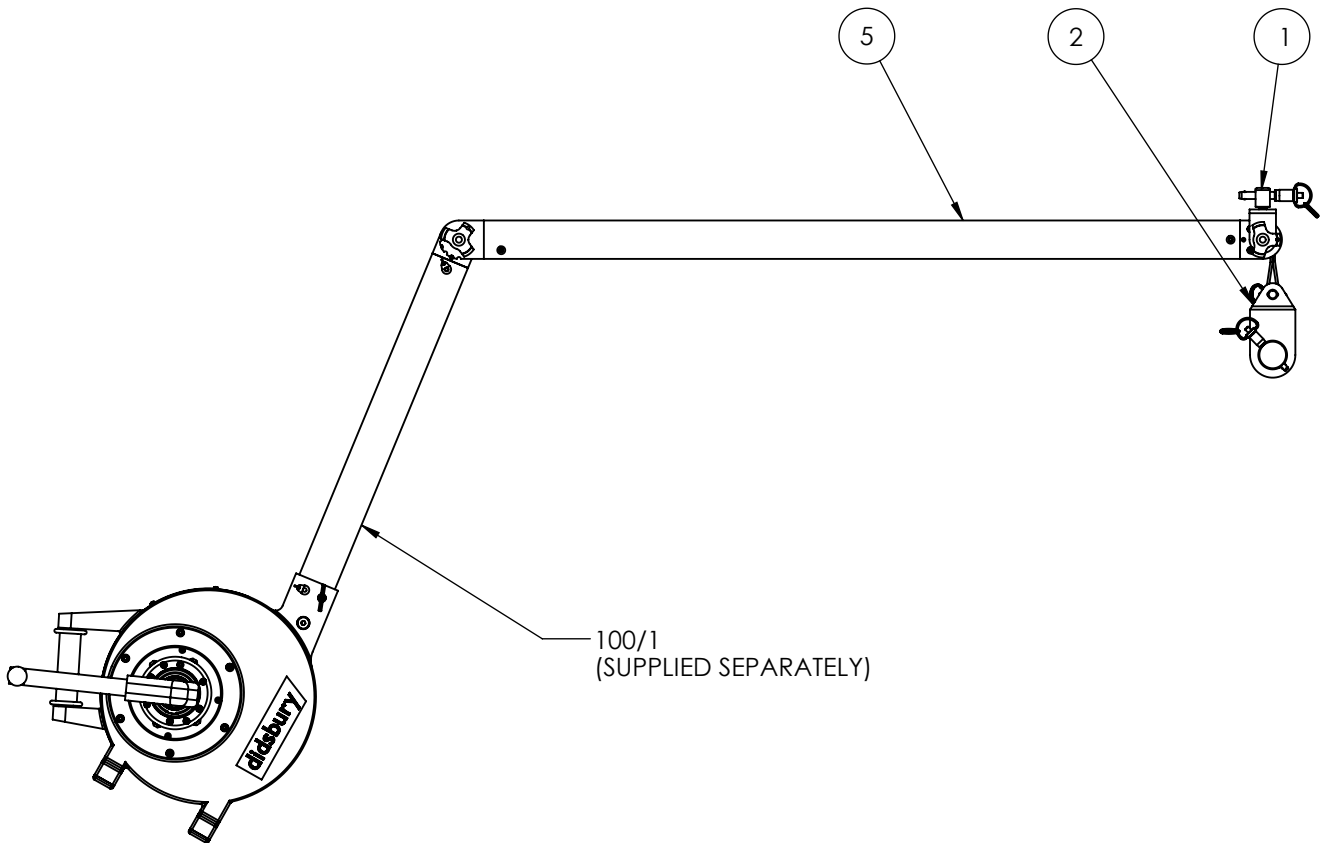

NOTE

REPLACE THE TOP SHEATH AND SHACKLE SUPPLIED WITH 100/1 WITH THE ITEMS SHOWN ABOVE

SWL: 100Kg

WEIGHT: 10Kg

HEIGHT OF LIFT: 13.2m

SHEET 2 of 7

AIRCRAFT APPLICATION SHEET FOR: 100/58

A400M AILERON S/C



World class lifting and handling solutions

Didsbury Engineering Co Ltd

Telephone: +44 (0)161 486 2200
Facsimile: +44 (0)161 486 2211
Email: sales@didsbury.com
Web: www.didsbury.com

ITEM NO.	PART No.	DESCRIPTION	QTY.
1	100/47	TOP SHEATH STRAP ASSEMBLY	1
3	100/49	AILERON S/C AND HTP ELEVATOR SC SHACKLE ASSY	1
5	100/77T2	1000mm EXTENSION TUBE ASSEMBLY	1

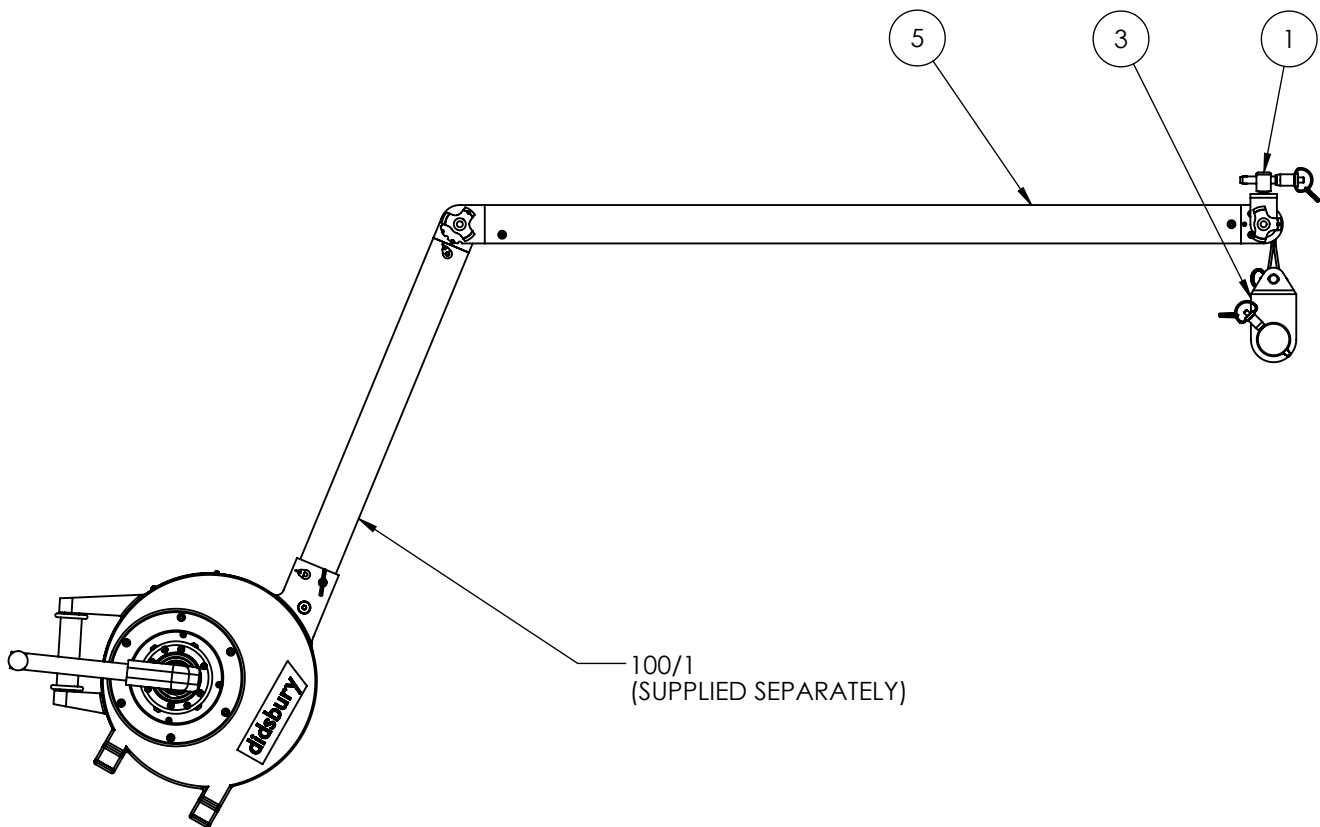

NOTE

REPLACE THE TOP SHEATH AND SHACKLE SUPPLIED WITH 100/1 WITH THE ITEMS SHOWN ABOVE

SWL: 100Kg

WEIGHT: 10Kg

HEIGHT OF LIFT: 13.2m

SHEET 3 of 7

AIRCRAFT APPLICATION SHEET FOR: 100/58

A400M SPOILER 1 EBHA

A400M SPOILER 2 S/C



World class lifting and handling solutions

Didsbury Engineering Co Ltd

Telephone: +44 (0)161 486 2200
Facsimile: +44 (0)161 486 2211
Email: sales@didsbury.com
Web: www.didsbury.com

ITEM NO.	PART NO.	DESCRIPTION	QTY.
1	100/47	TOP SHEATH STRAP ASSEMBLY	1
4	100/50	SPOILER 1 AND 2 AND HTP ELEVATOR EHA SHACKLE ASSY	1
5	100/77T2	1000mm EXTENSION TUBE ASSEMBLY	1

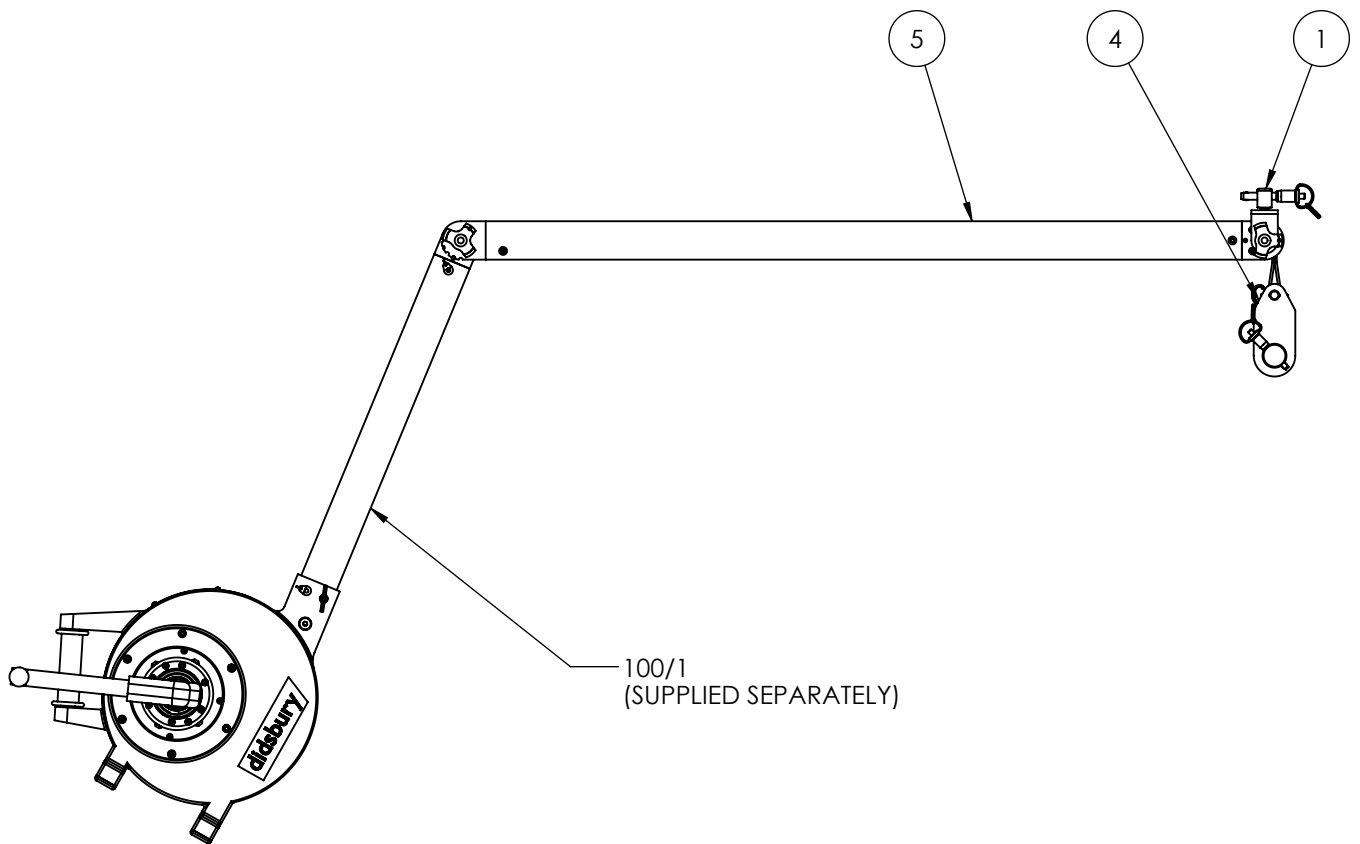

NOTE

REPLACE THE TOP SHEATH AND SHACKLE SUPPLIED WITH 100/1 WITH THE ITEMS SHOWN ABOVE

SWL: 100Kg

WEIGHT: 10Kg

HEIGHT OF LIFT: 13.2m

SHEET 4 of 7

AIRCRAFT APPLICATION SHEET FOR: 100/58

A400M HTP ELEVATOR S/C



World class lifting and handling solutions

Didsbury Engineering Co Ltd

Telephone: +44 (0)161 486 2200
Facsimile: +44 (0)161 486 2211
Email: sales@didsbury.com
Web: www.didsbury.com

ITEM NO.	PART No.	DESCRIPTION	QTY.
1	100/47	TOP SHEATH STRAP ASSEMBLY	1
3	100/49	AILERON S/C AND HTP ELEVATOR SC SHACKLE ASSY	1
5	100/77T2	1000mm EXTENSION TUBE ASSEMBLY	1
6	100/31T7	1200mm LONG BASE TUBE ASSEMBLY	1

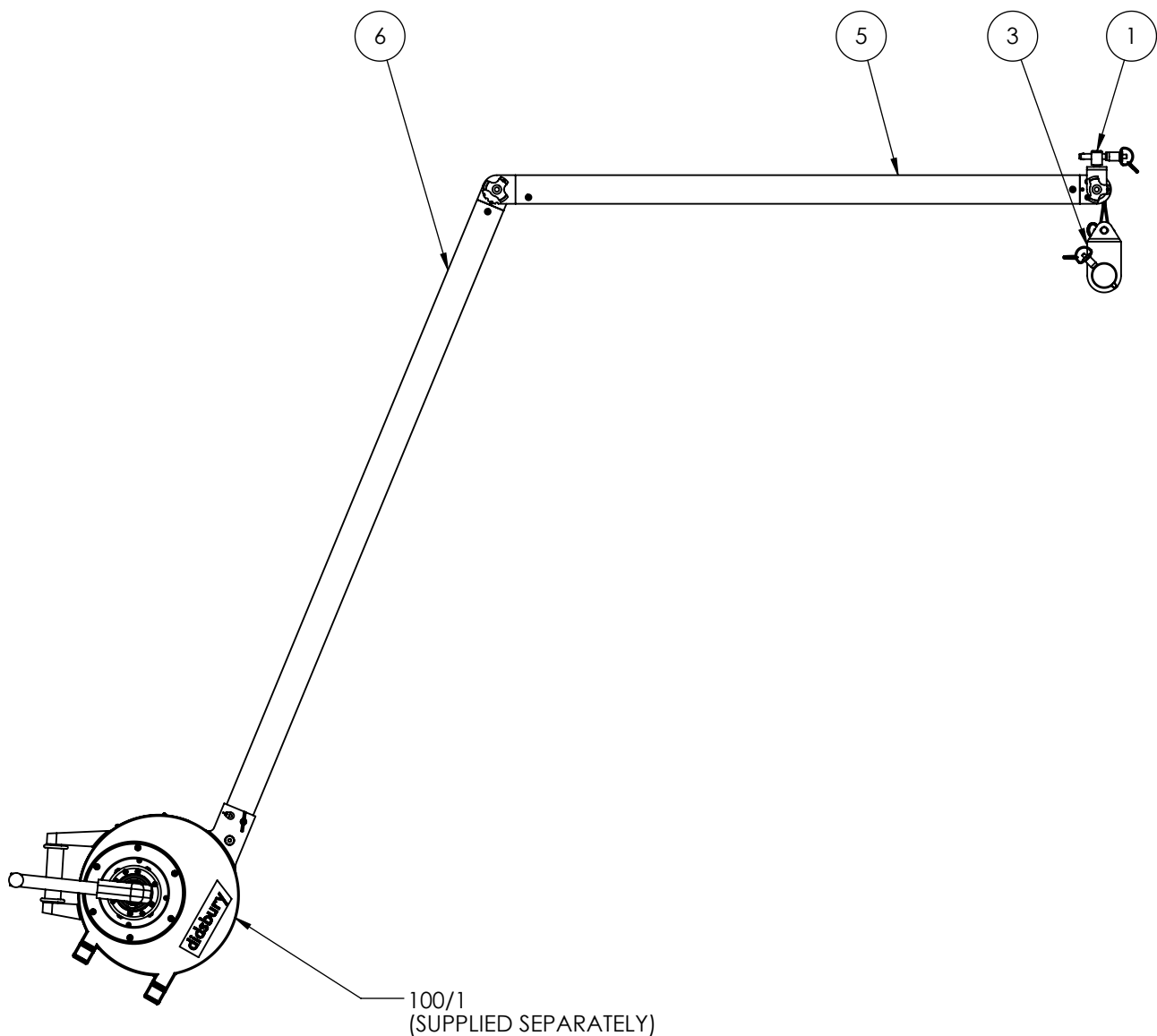

NOTE

REPLACE THE BASE TUBE, TOP SHEATH AND SHACKLE SUPPLIED WITH 100/1 WITH THE ITEMS SHOWN ABOVE

SWL: 100Kg

WEIGHT: 10Kg

HEIGHT OF LIFT: 12.5m

SHEET 5 of 7

AIRCRAFT APPLICATION SHEET FOR: 100/58

A400M HTP ELEVATOR EHA



World class lifting and handling solutions

Didsbury Engineering Co Ltd

Telephone: +44 (0)161 486 2200
Facsimile: +44 (0)161 486 2211
Email: sales@didsbury.com
Web: www.didsbury.com

ITEM NO.	PART No.	DESCRIPTION	QTY.
1	100/47	TOP SHEATH STRAP ASSEMBLY	1
4	100/50	SPOILER 1 AND 2 AND HTP ELEVATOR EHA SHACKLE ASSY	1
5	100/77T2	1000mm EXTENSION TUBE ASSEMBLY	1
6	100/31T7	1200mm LONG BASE TUBE ASSEMBLY	1

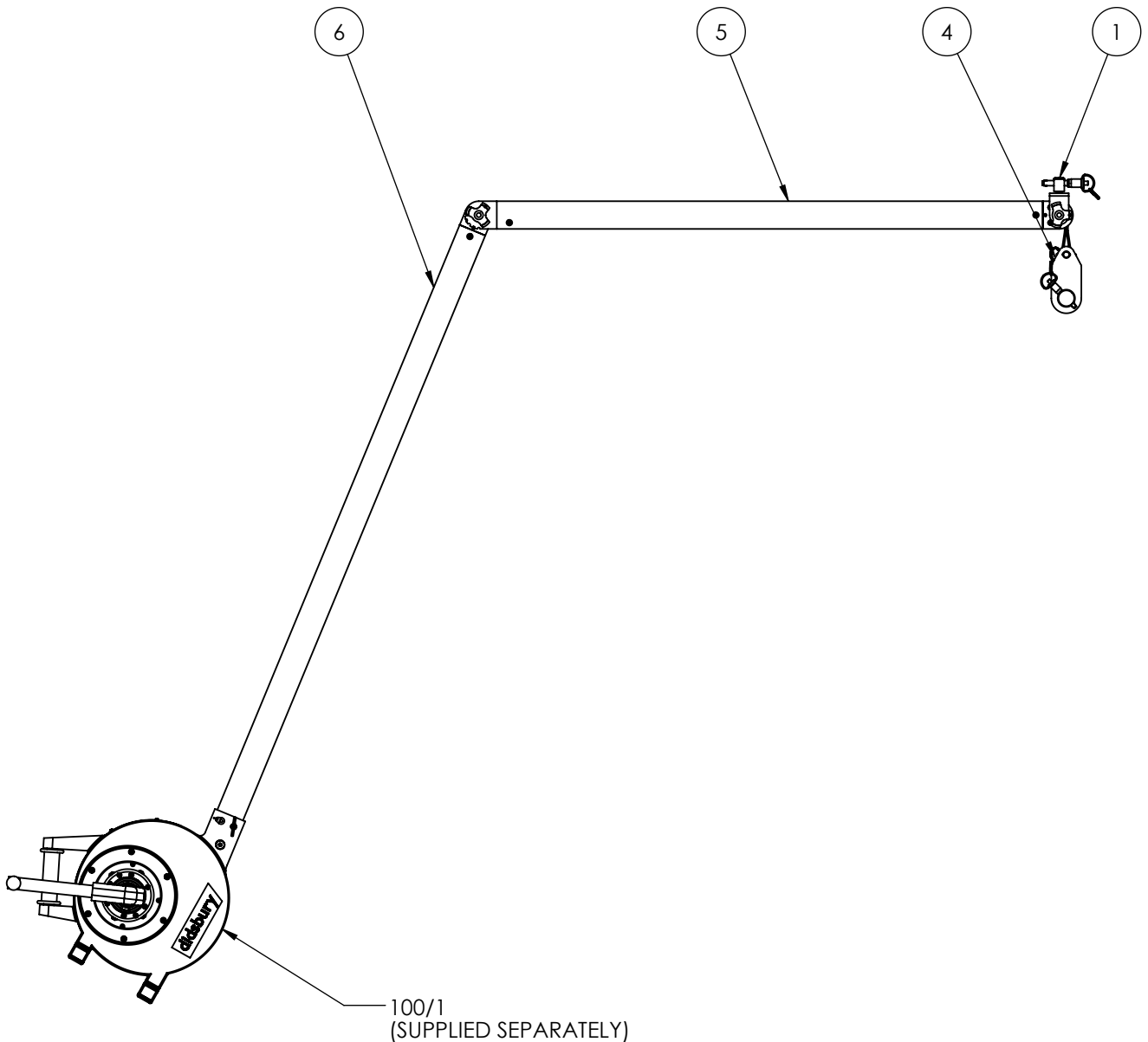

NOTE

REPLACE THE BASE TUBE, TOP SHEATH AND SHACKLE SUPPLIED WITH 100/1 WITH THE ITEMS SHOWN ABOVE

SWL: 100Kg
WEIGHT: 10Kg

HEIGHT OF LIFT: 12.5m

SHEET 6 of 7

AIRCRAFT APPLICATION SHEET FOR: 100/58

A400M PICK UP TOOL



World class lifting and handling solutions

Didsbury Engineering Co Ltd

Telephone: +44 (0)161 486 2200
Facsimile: +44 (0)161 486 2211
Email: sales@didsbury.com
Web: www.didsbury.com

ITEM NO.	PART No.	DESCRIPTION	QTY.
1	100/47	TOP SHEATH STRAP ASSEMBLY	1
5	100/77T2	1000mm EXTENSION TUBE ASSEMBLY	1
6	100/31T7	1200mm LONG BASE TUBE ASSEMBLY	1

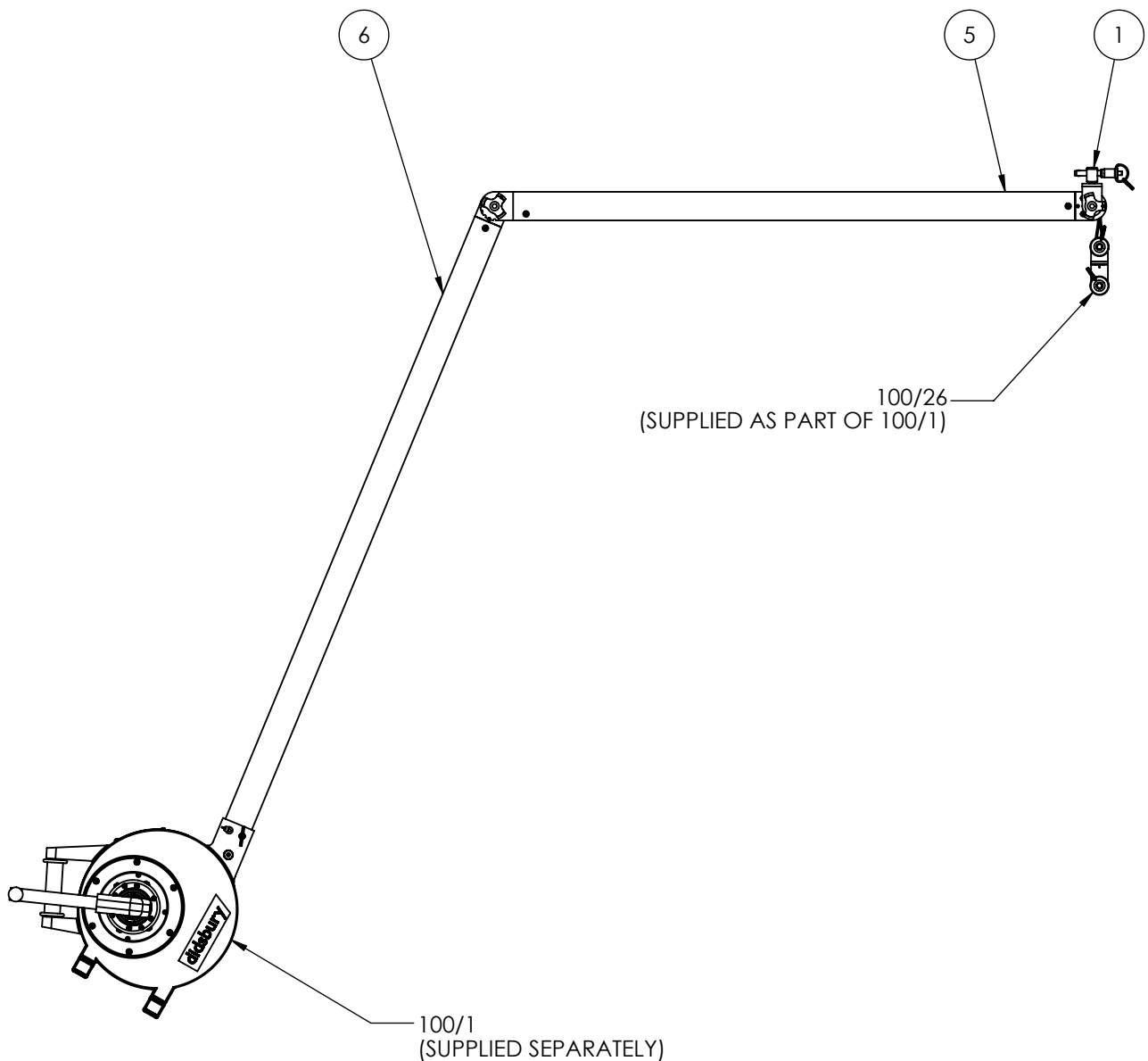

NOTE

REPLACE THE BASE TUBE AND TOP SHEATH SUPPLIED WITH 100/1 WITH THE ITEMS SHOWN ABOVE

SWL: 100Kg

WEIGHT: 10Kg

HEIGHT OF LIFT: 12.5m

SHEET 7 of 7