

AIRCRAFT APPLICATION SHEET FOR: 100/1 LIGHTWEIGHT TAPE HOIST



World class lifting and handling solutions

Didsbury Engineering Co Ltd

Telephone: +44 (0)161 486 2200
 Facsimile: +44 (0)161 486 2211
 Email: sales@didsbury.com
 Web: www.didsbury.com

A350 HTP ELEVATOR ACTUATORS
 A380 WING FAIRINGS
 A380 RAM AIR TURBINE
 A380 ELEVATOR ACTUATORS
 A400M R/I ACTUATOR
 A400M DEVICE TO STRETCH INNER MOBILE PANEL (2 HOIST LIFT)

ITEM NO.	PART No.	DESCRIPTION	QTY.
1	92/274	WINDING HANDLE	1
2	100/26	SHACKLE ASSEMBLY	1
3	100/31T1	EXTENSION TUBE ASSEMBLY	1
4	100/44	SINGLE FALL TOP SHEATH ASSEMBLY	1
5	100/43	TAPE HOIST WINDING MECHANISM	1
6	5-2480	STRAP 25mm WIDE x 15M LONG	1

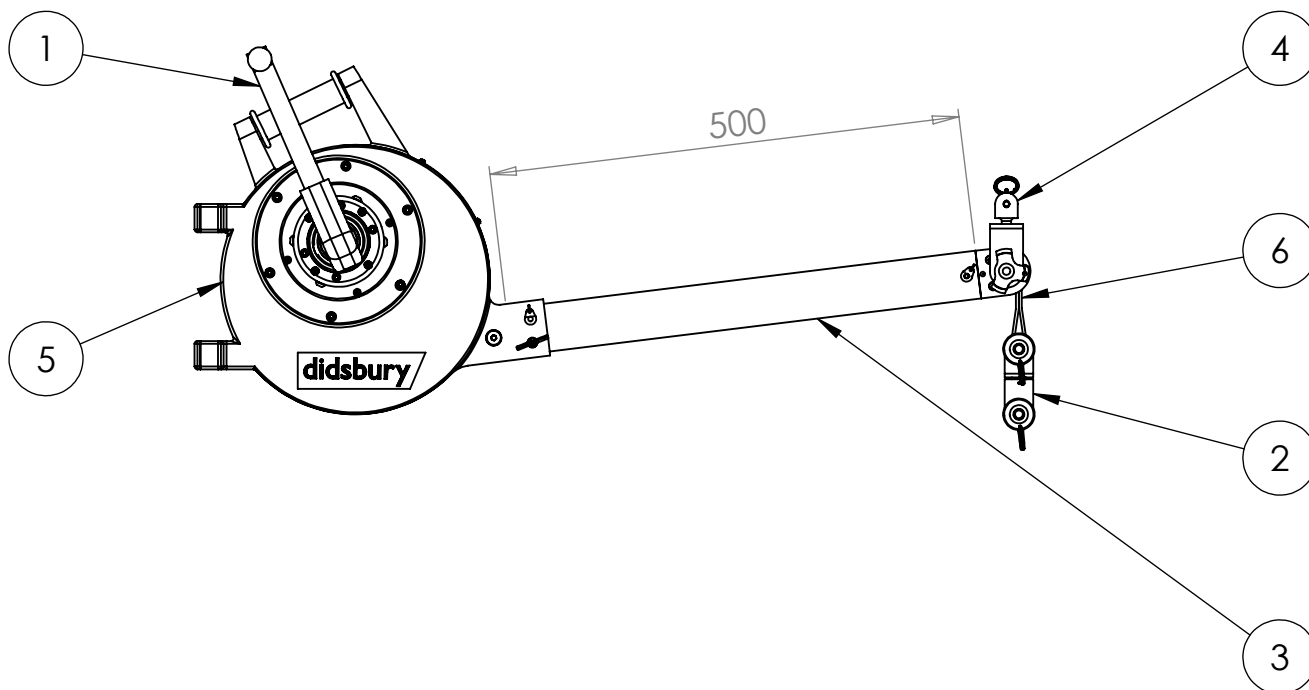

SWL: 100Kg
 WEIGHT: 10Kg

HEIGHT OF LIFT: 14.2 M